

Computer Science CSCI 355

Digital Logic and Computer Organization

Dr. Peter Walsh

Department of Computer Science

Vancouver Island University

peter.walsh@viu.ca

Edge Triggered Flip Flops (FF)

- Positive Edge Triggered
 - outputs are generated on the rising edge
- Negative Edge Triggered
 - outputs are generated on the falling edge

Negative Edge Triggered D FF

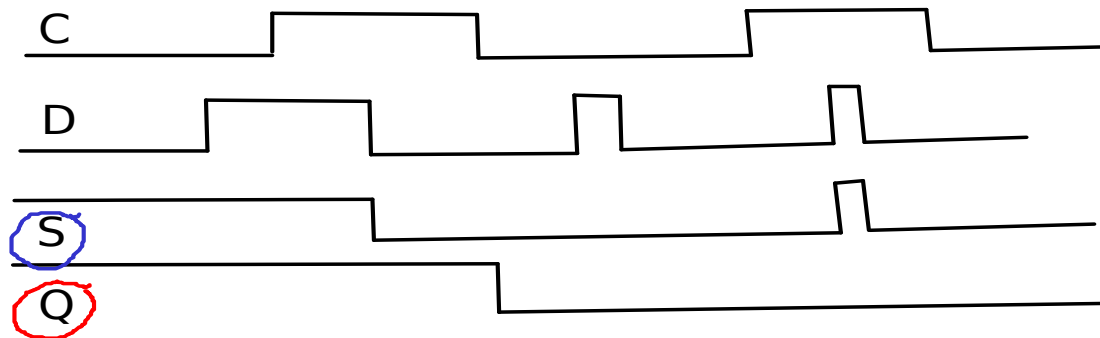
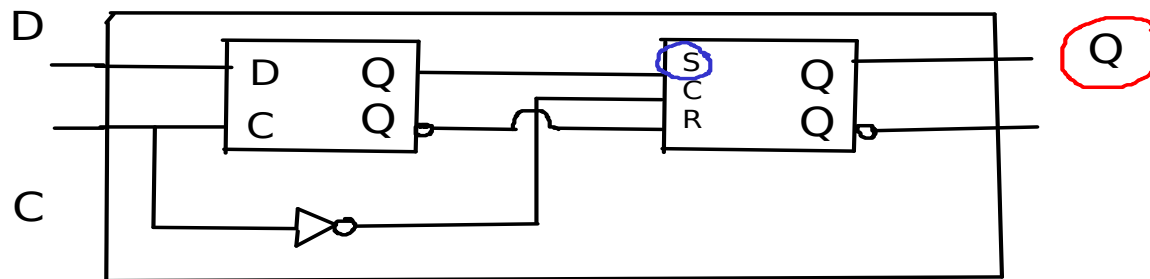

Edge Triggered FFs (Block Diagrams)

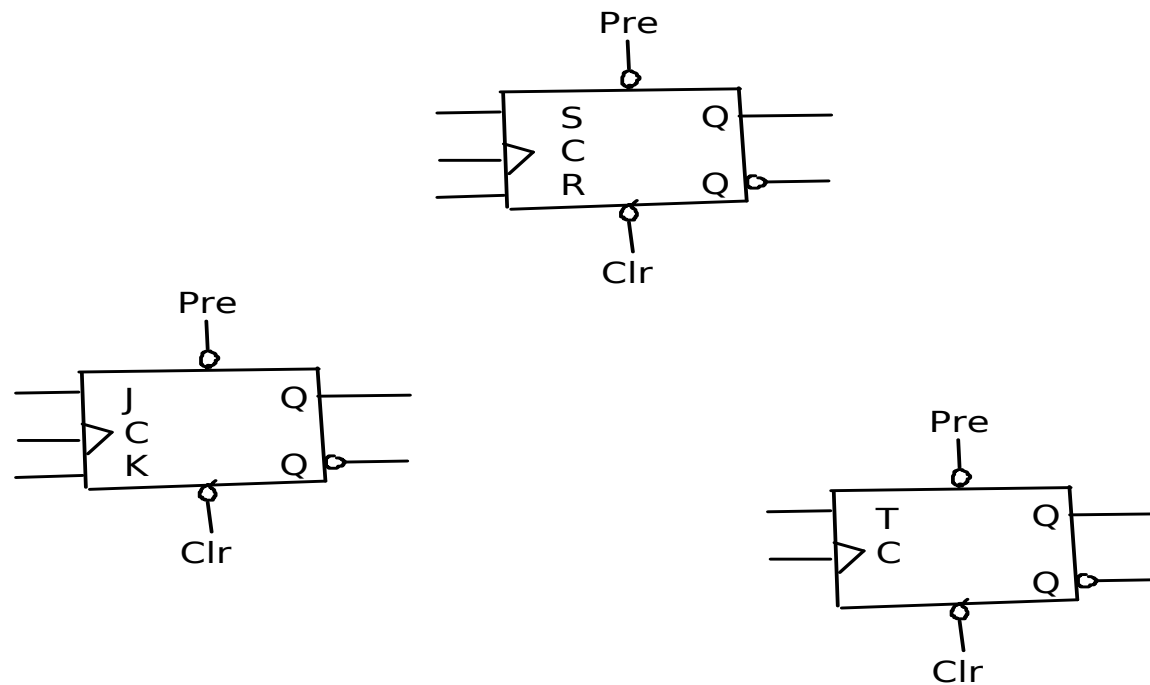

SR Edge Triggered FF

$$Q^+ = S + R'Q$$

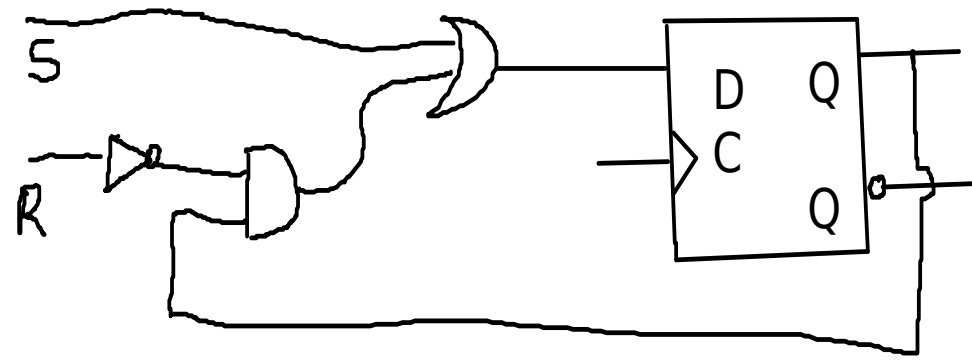

JK Edge Triggered FF

$$Q^+ = JQ' + K'Q$$

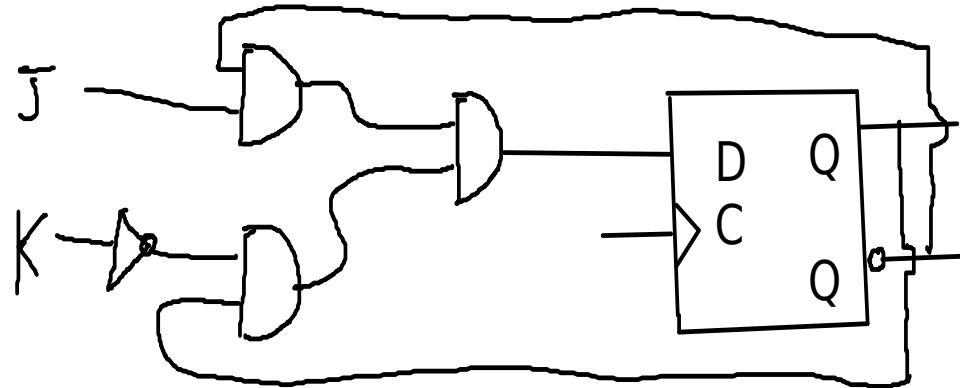

T Edge Triggered FF

$$Q^+ = T \oplus Q$$

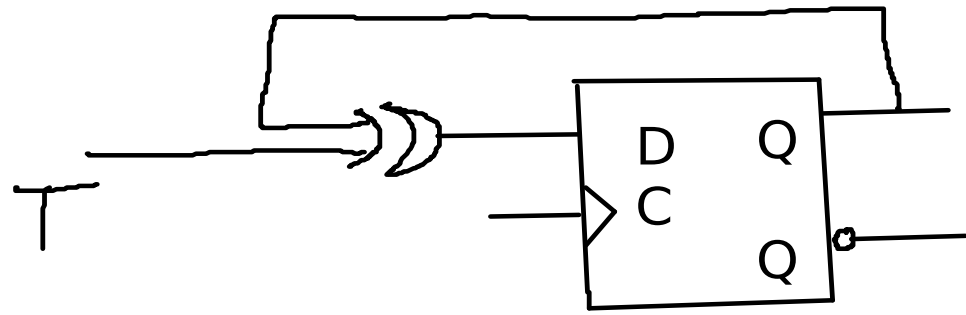

Hazards

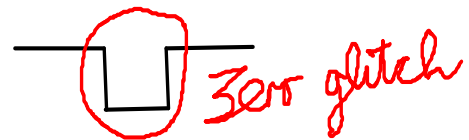

Static 1 - 1 Hazard

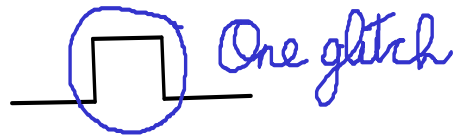

Static 0 - 0 Hazard

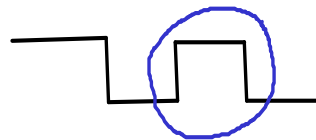

Dynamic 1 - 0 Hazard

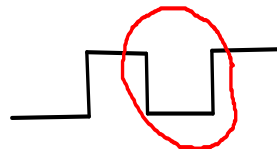

Dynamic 0 - 1 Hazard

Static Hazard

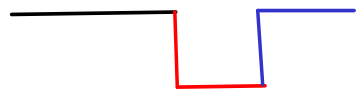
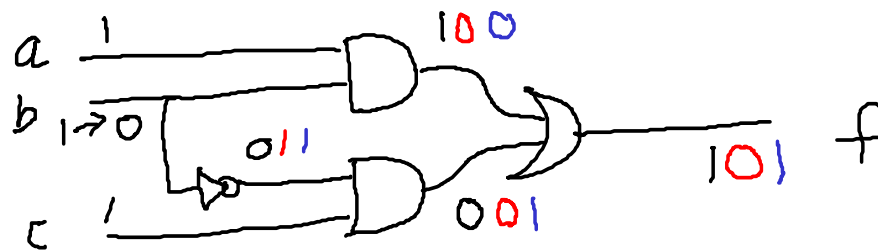

Static 1 - 1 Hazard
(0 glitch)

One gate delay

Two gate delays

Static Hazard cont.

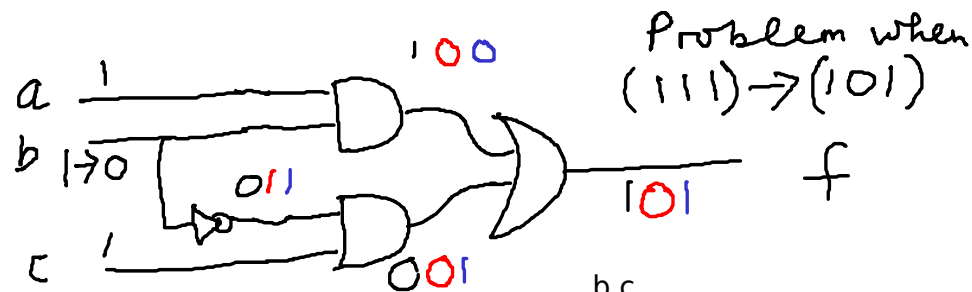

$$f = ab + \bar{b}c$$

	bc			
	00	01	11	10
a		1		
0		1		
1		1	1	1

One gate delay
Two gate delays

$$f = ab + \bar{b}c + ac$$

Static Hazard cont.

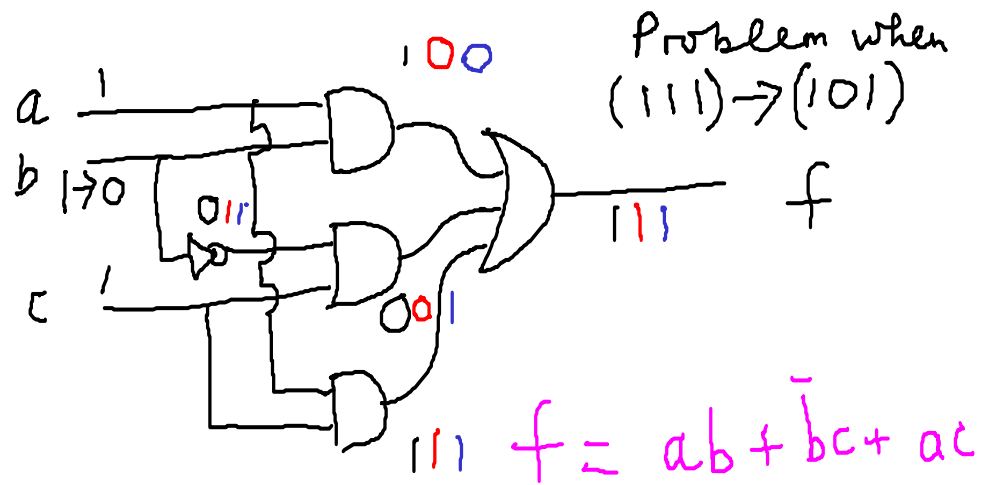

One gate delay

Two gate delays

Debouncing

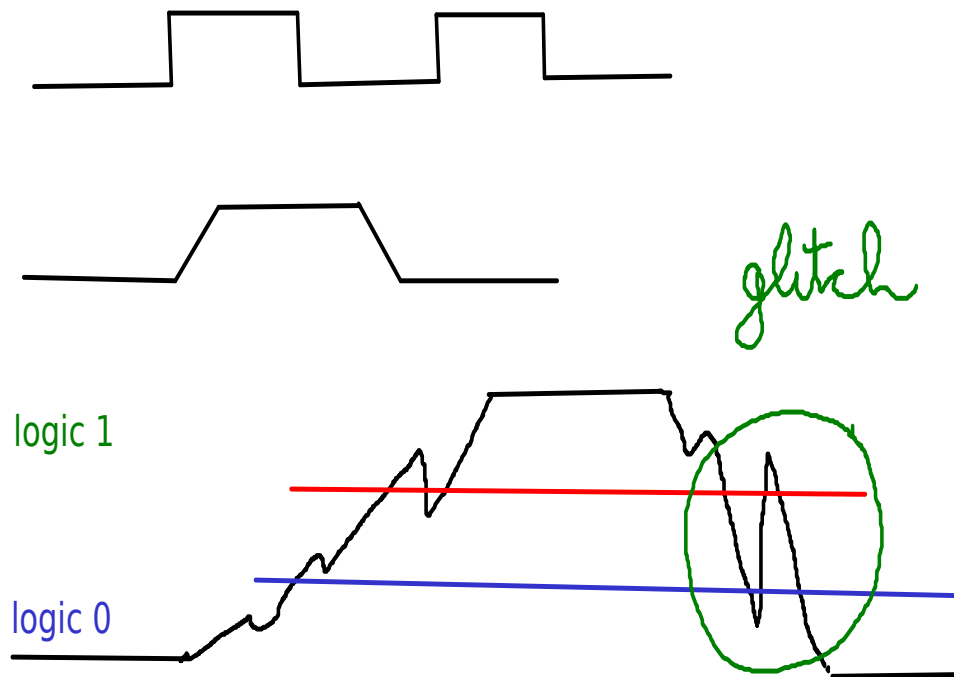

Debouncing cont.

